

 Lichtblau RAL 5012

 Weiß

Bremsklappen ausgefahren

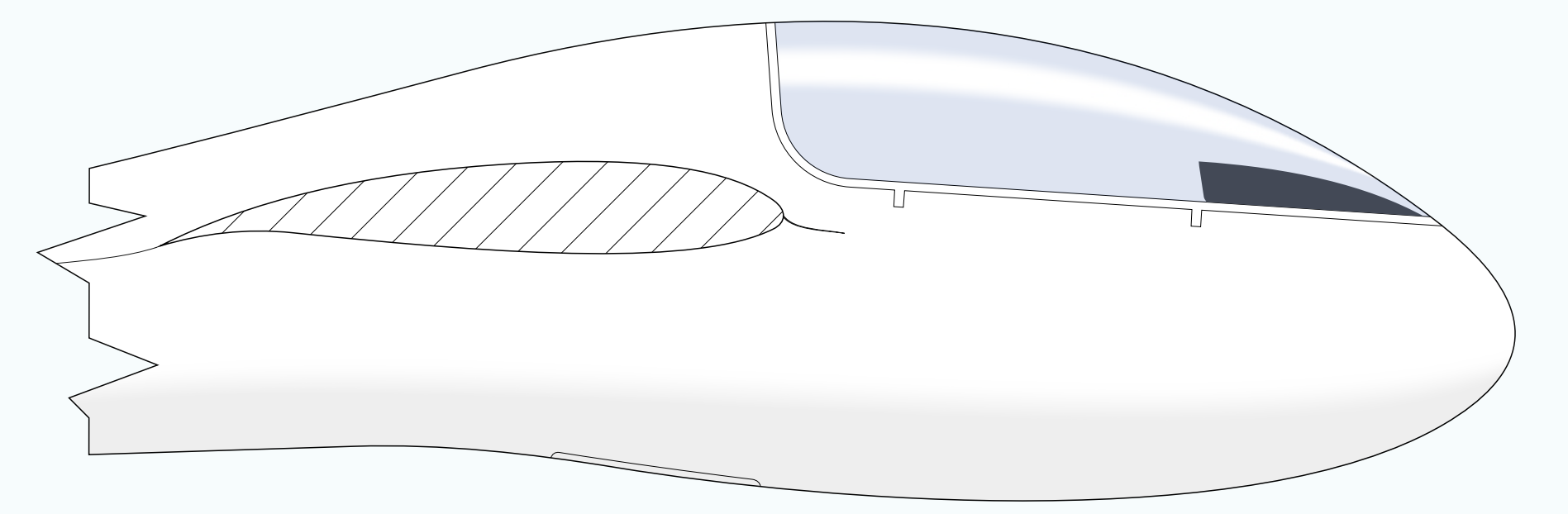

Maßstab/Scale

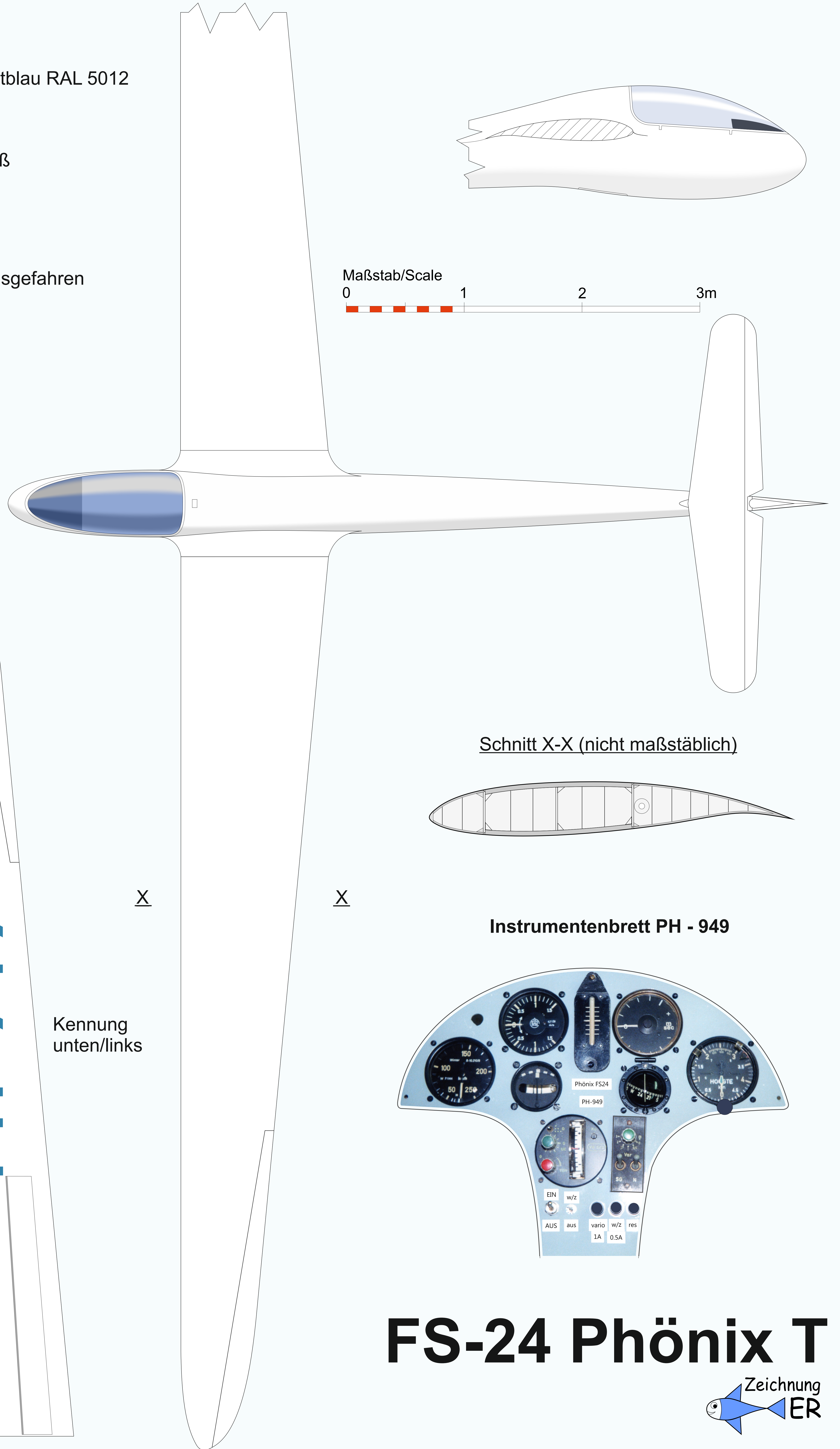
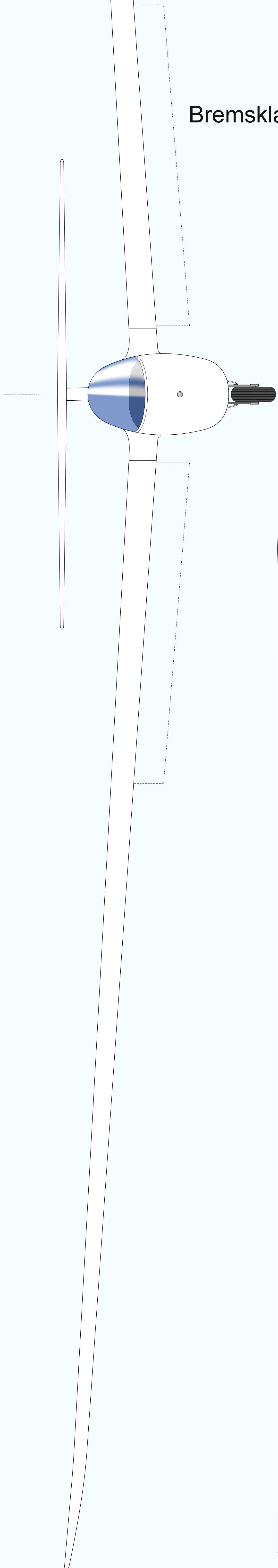

Schnitt X-X (nicht maßstäblich)

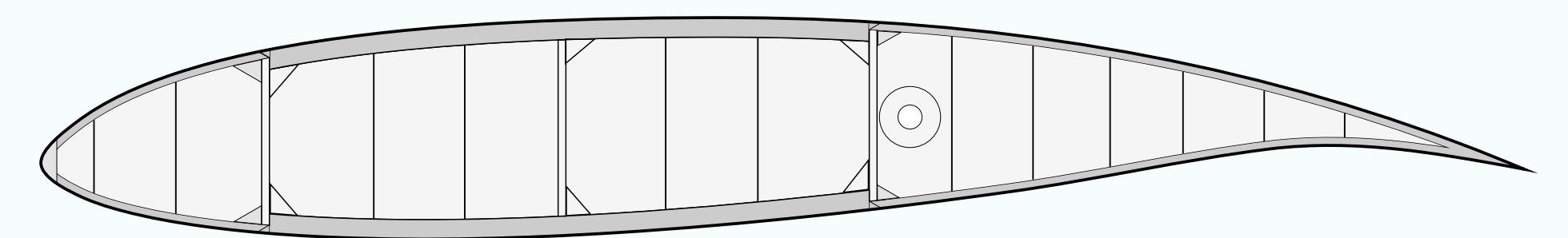

Instrumentenbrett PH - 949

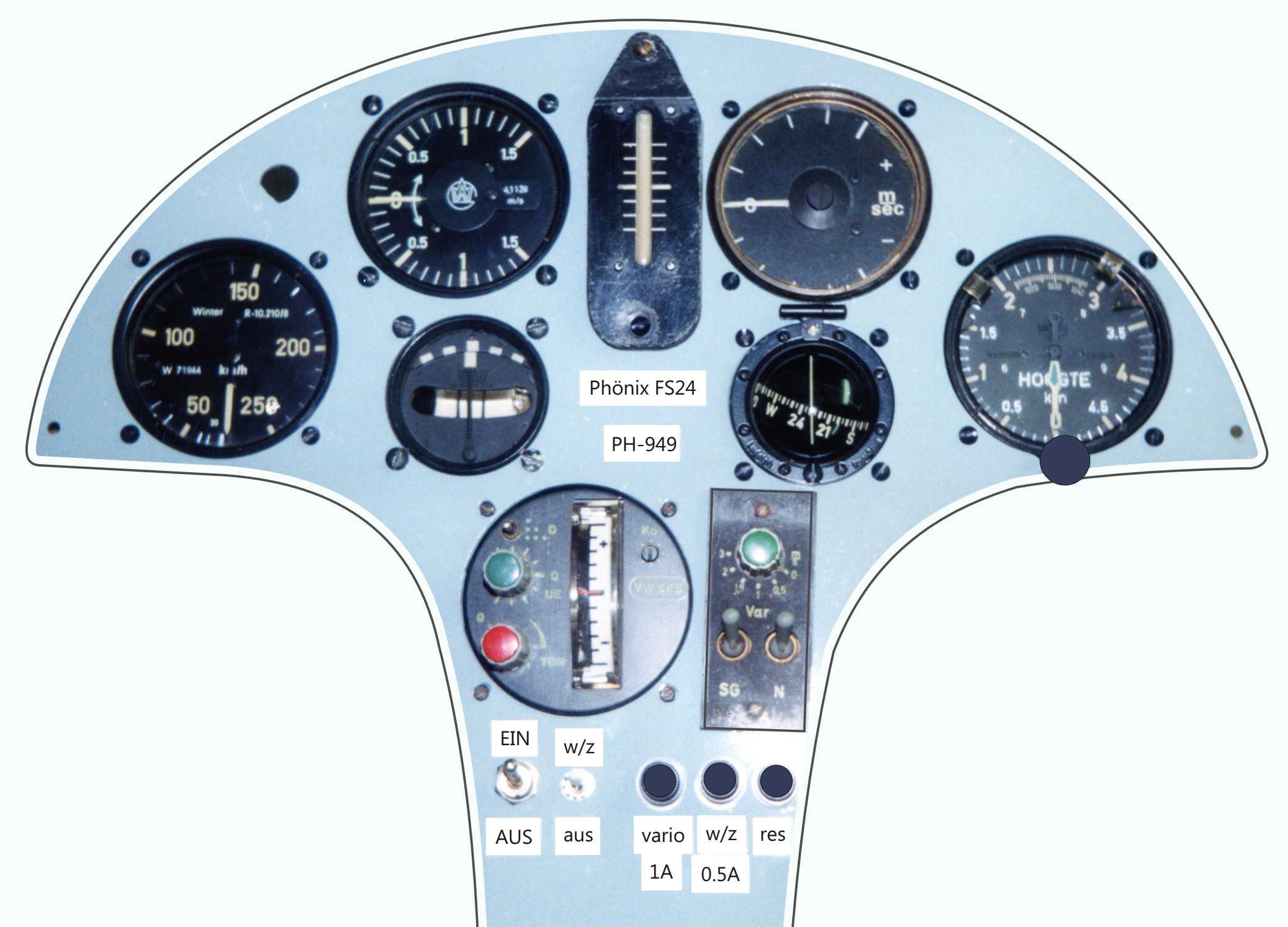

PH-949

Kennung unten/links

**FS-24 Phönix T**

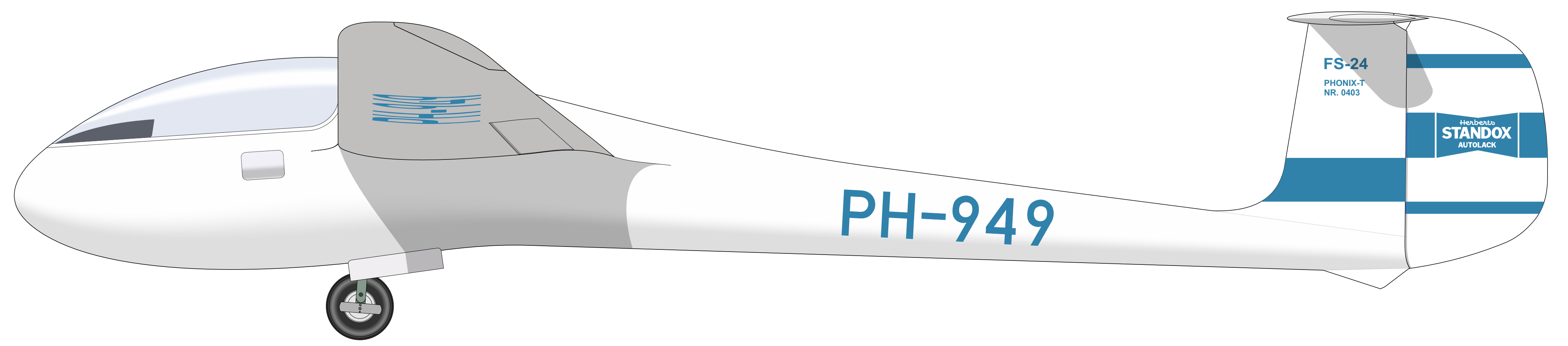

 Lichtblau RAL 5012

 Weiß

Bremsklappen ausgefahren

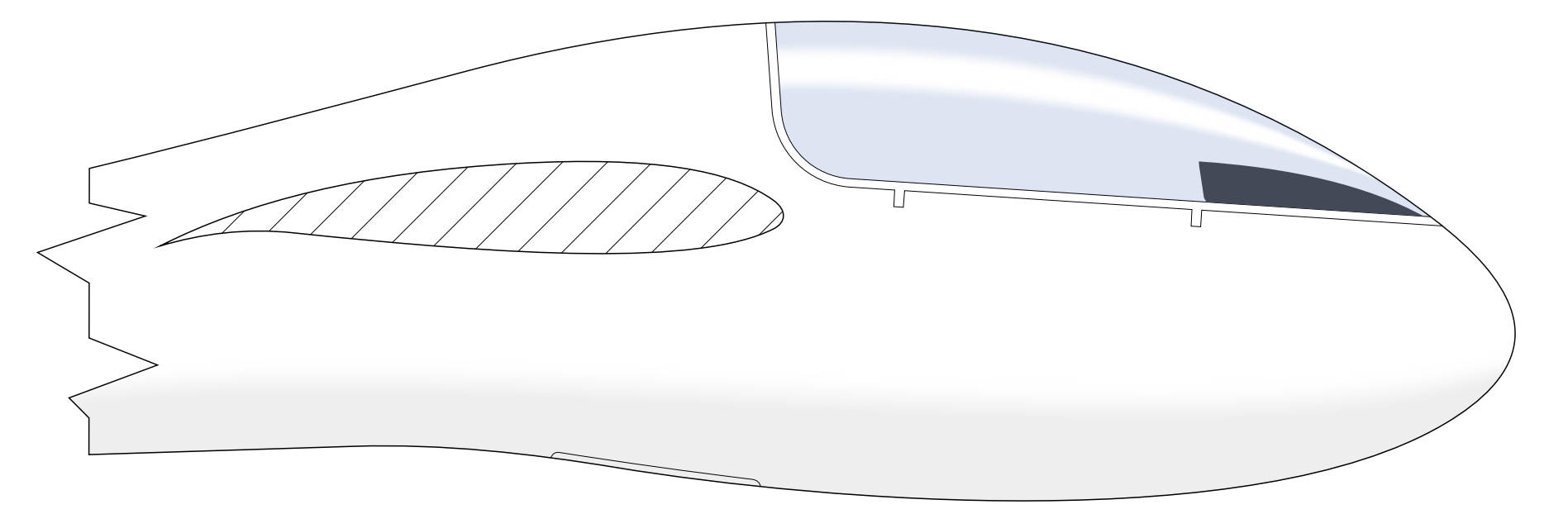

Maßstab/Scale

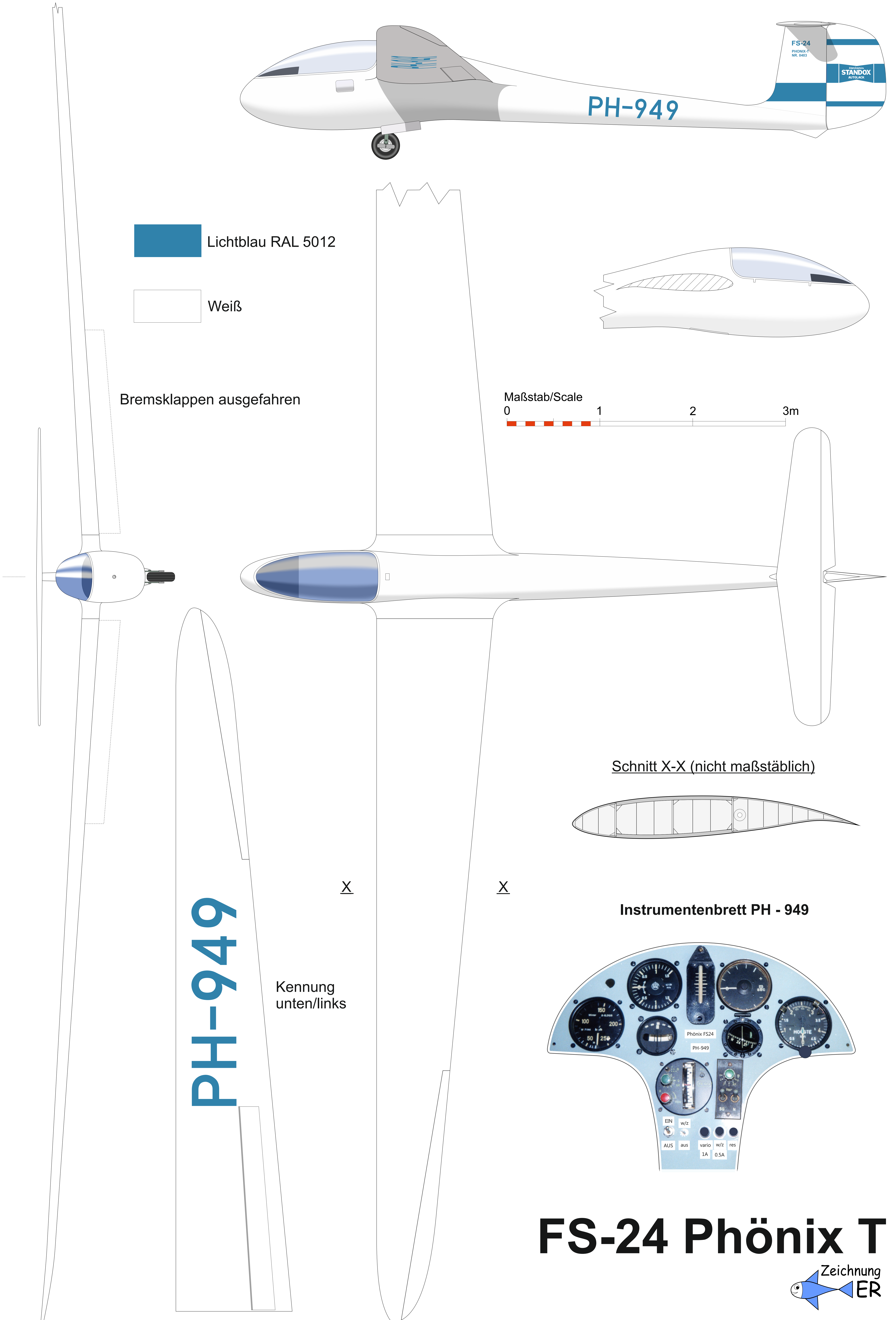

Schnitt X-X (nicht maßstäblich)

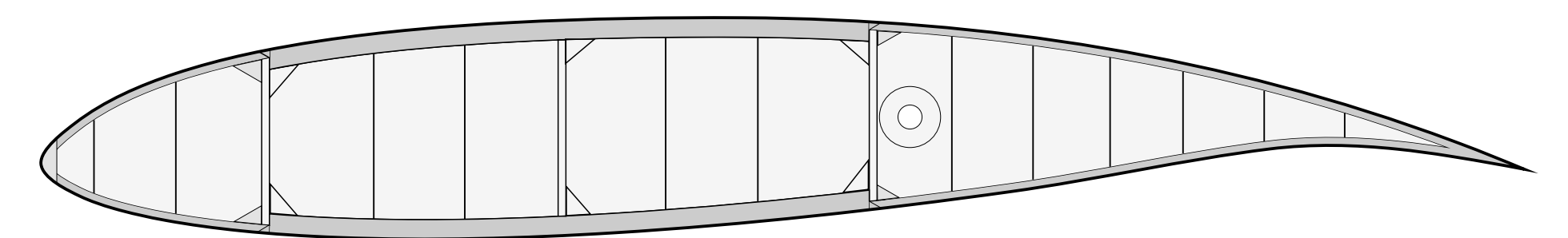

Instrumentenbrett PH - 949



PH-949

Kennung unten/links

# FS-24 Phönix T

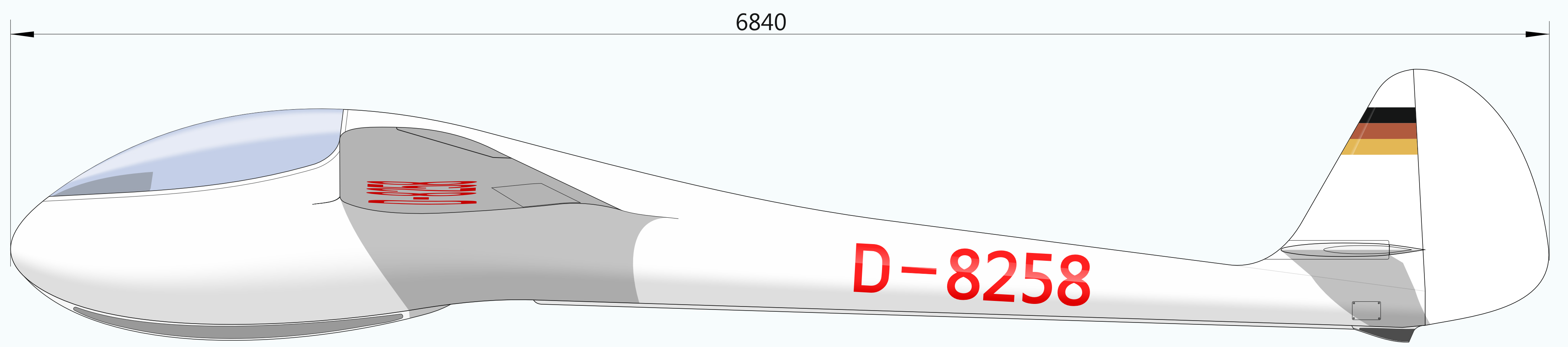
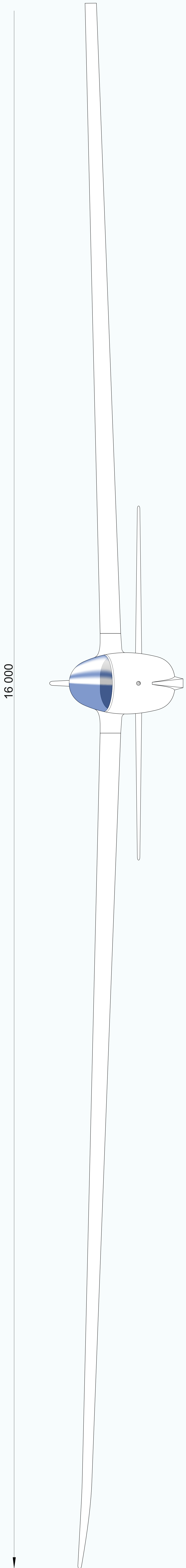

Schnitt X- X (Maßstab x 2)

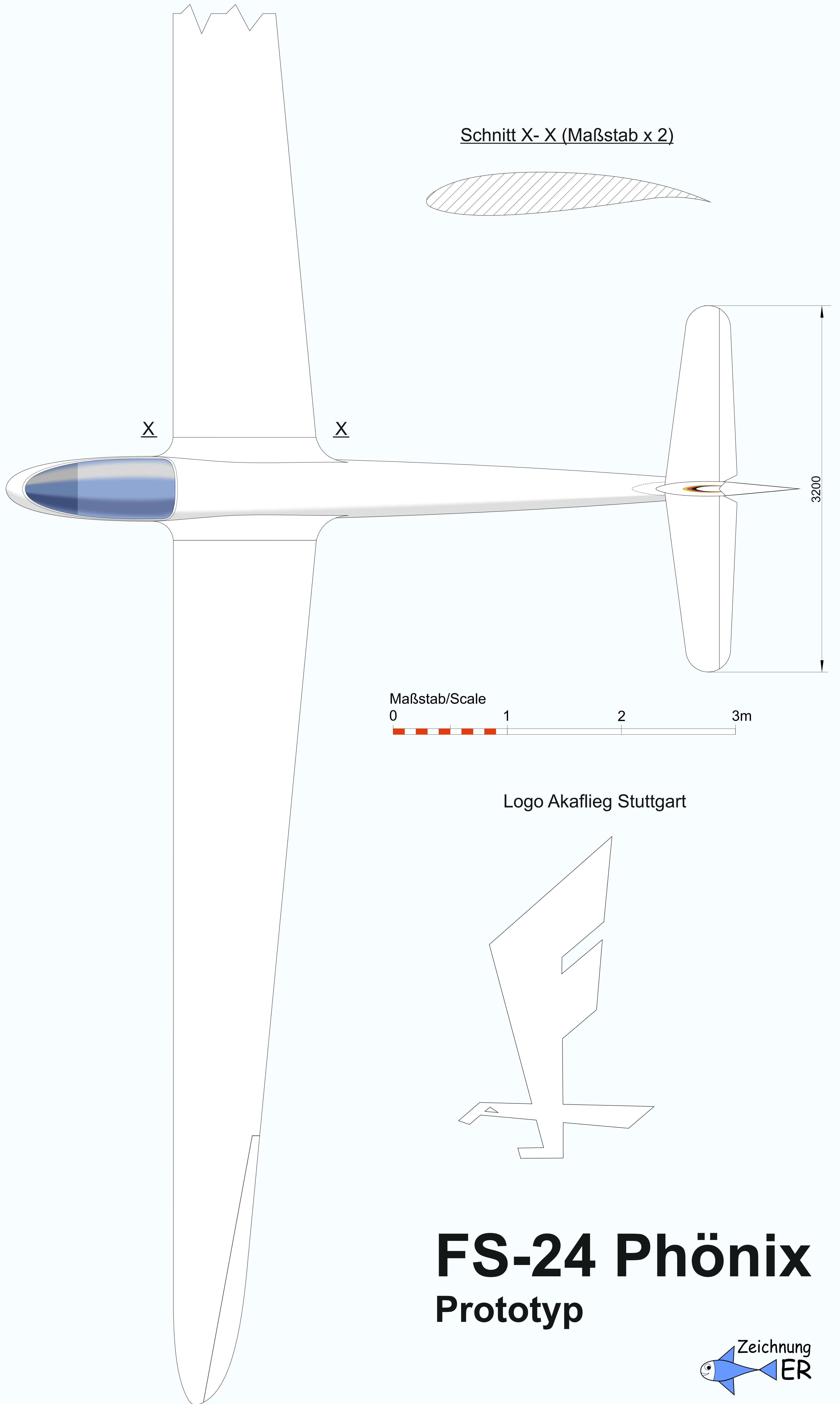
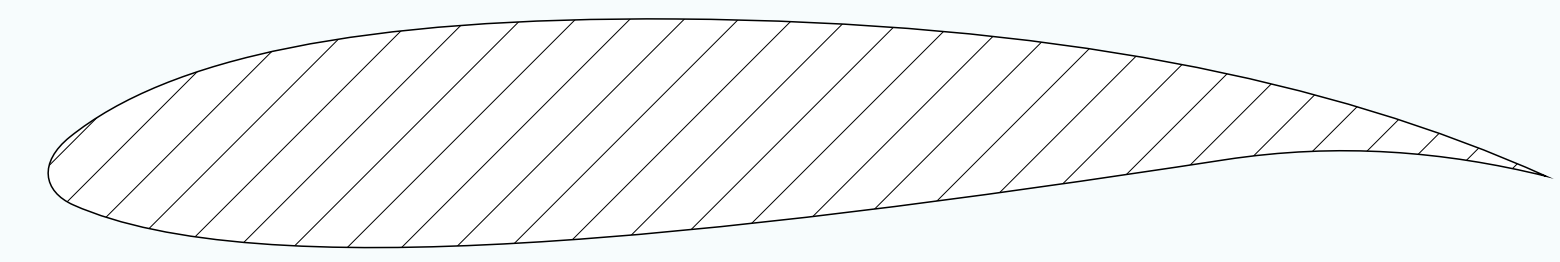

Maßstab/Scale  
0 1 2 3m

Logo Akaflieg Stuttgart

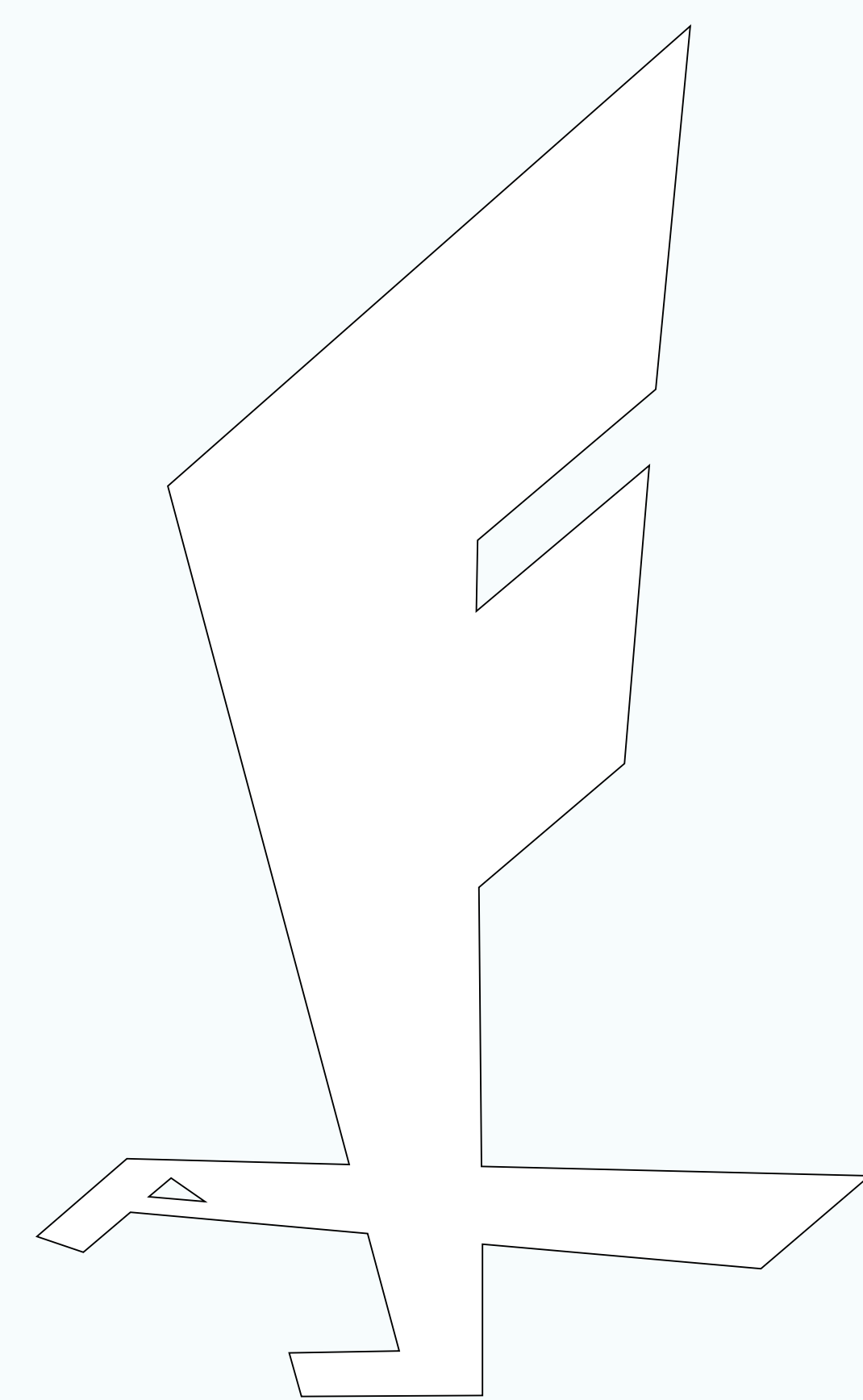

# FS-24 Phönix

## Prototyp


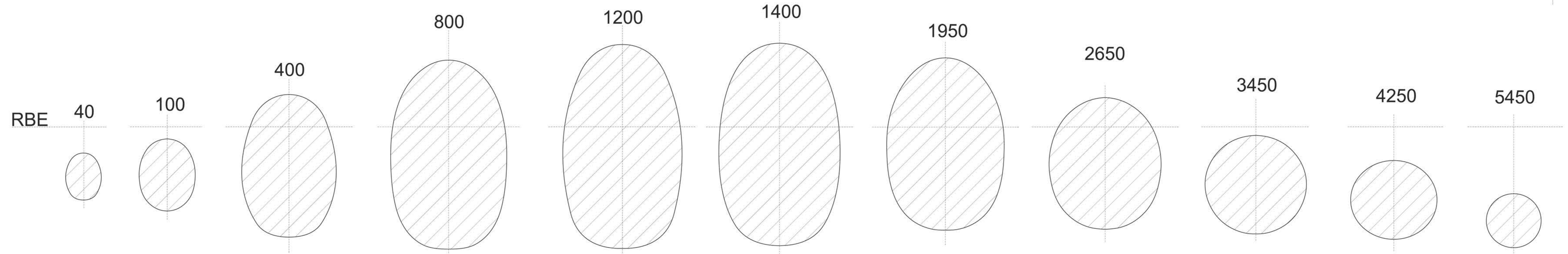


# FS-24 Phönix T

Bauteilübersicht  
Rumpf/Rumpfschnitte



**Schnitt A - A**

Flügel-und Leitwerksschnitte  
Maßstab x 2

**A**

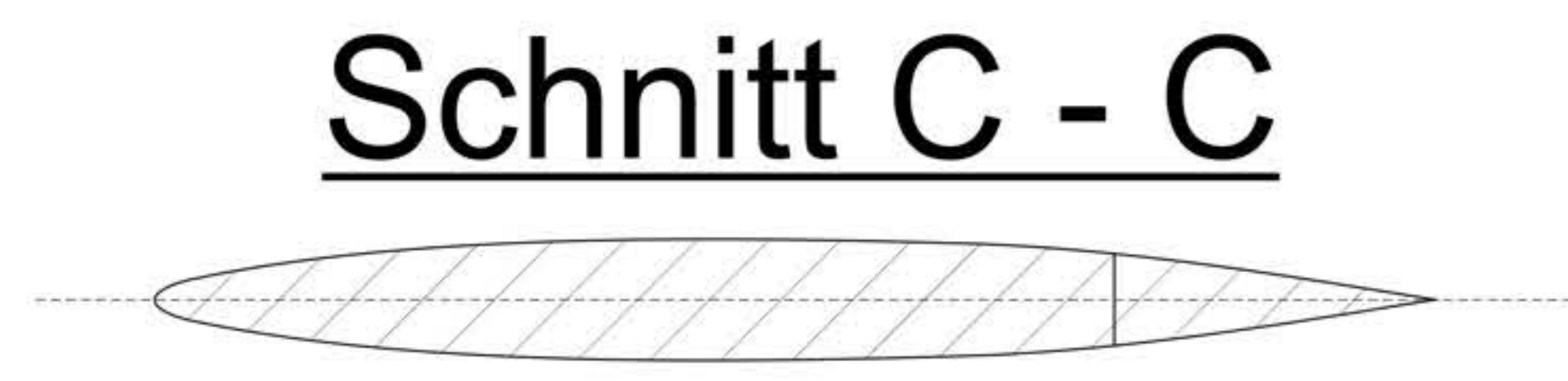

**Schnitt C - C**

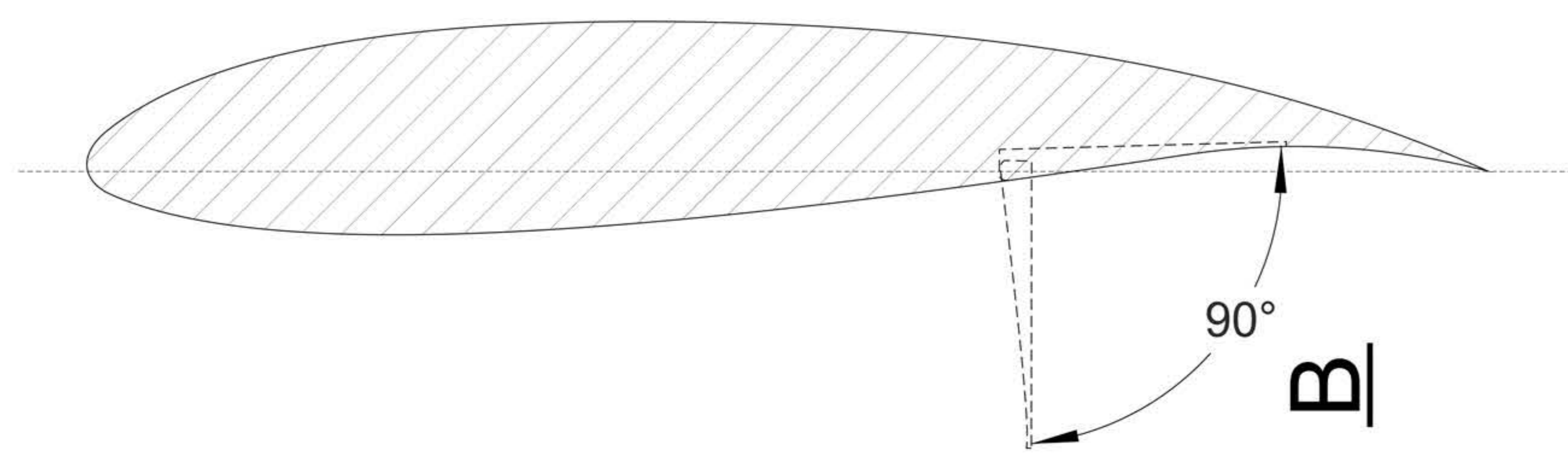

**B**



**B**

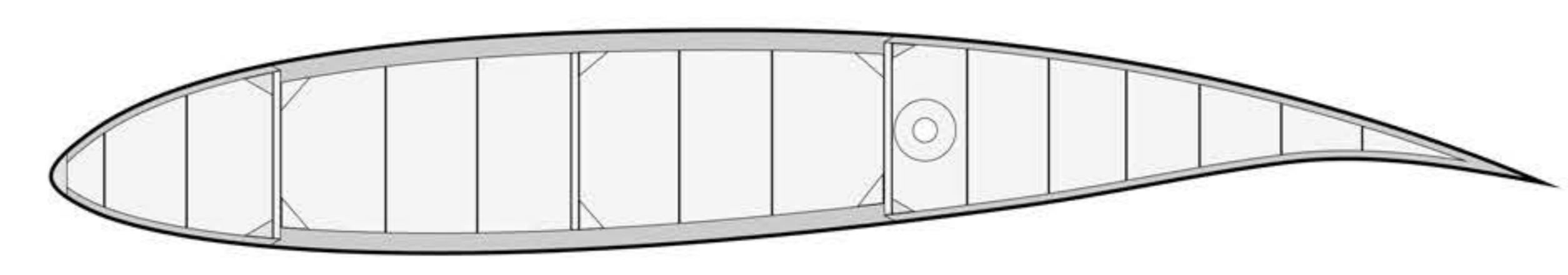

**Schnitt B - B**

**A**

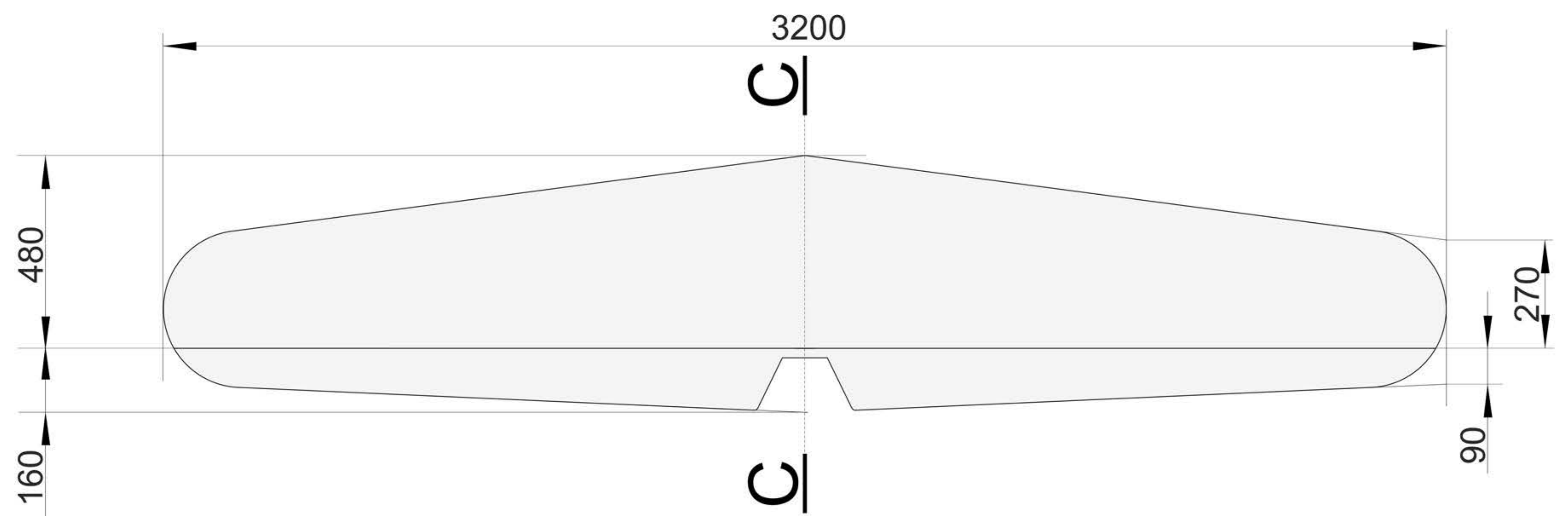

**C**

**C**



# FS-24 Phönix T

Bauteilübersicht  
Tragfläche/Höhenleitwerk



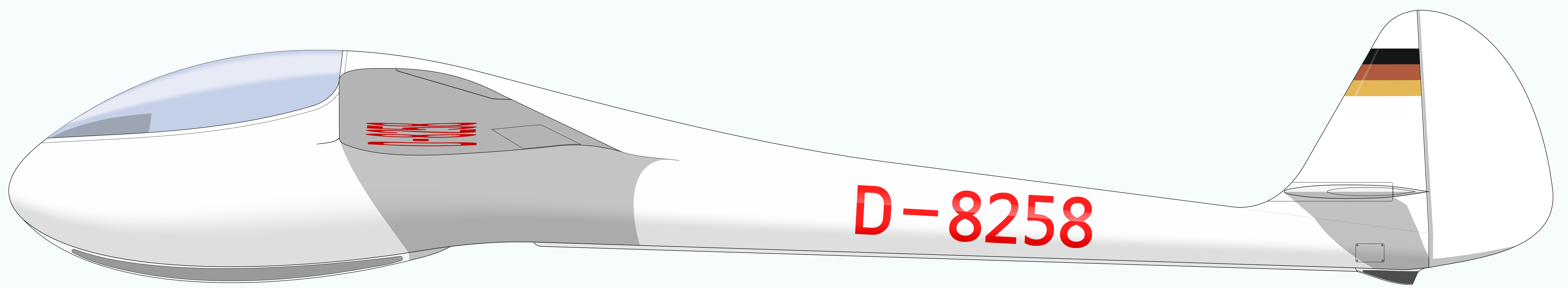

Prototyp FS-24 Phönix

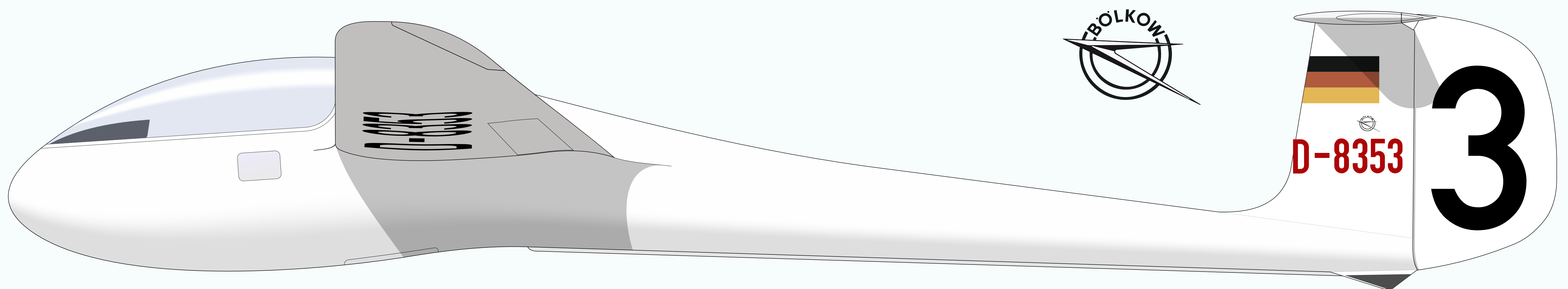

D-8353, Werknummer 402  
Segelflug Weltmeisterschaft Köln 1960  
(Pilot: Ernst Günther Haase)

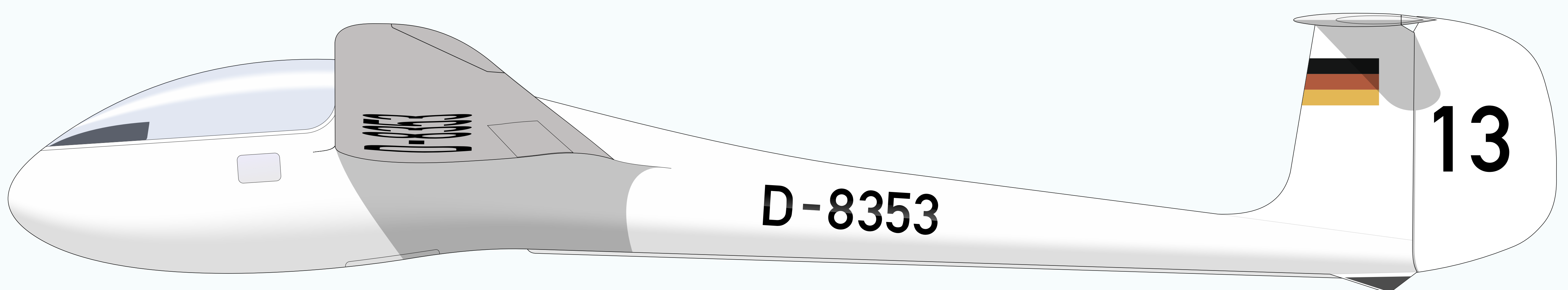

70er Jahre Hahnweide Kirchheim/Teck.

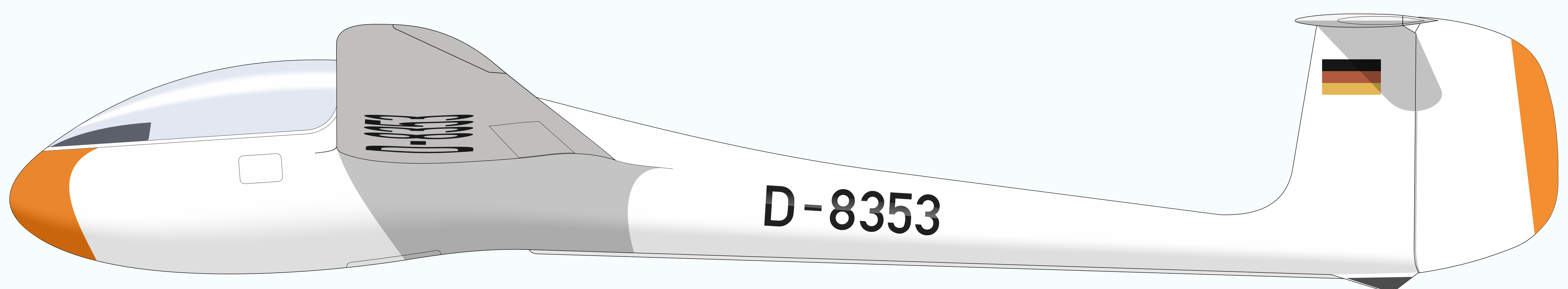

ab Oktober 1987 Segelflugmuseum  
Wasserkuppe



Maßstab/Scale



**FS-24 Phönix T**

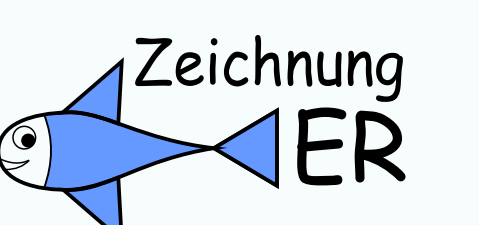

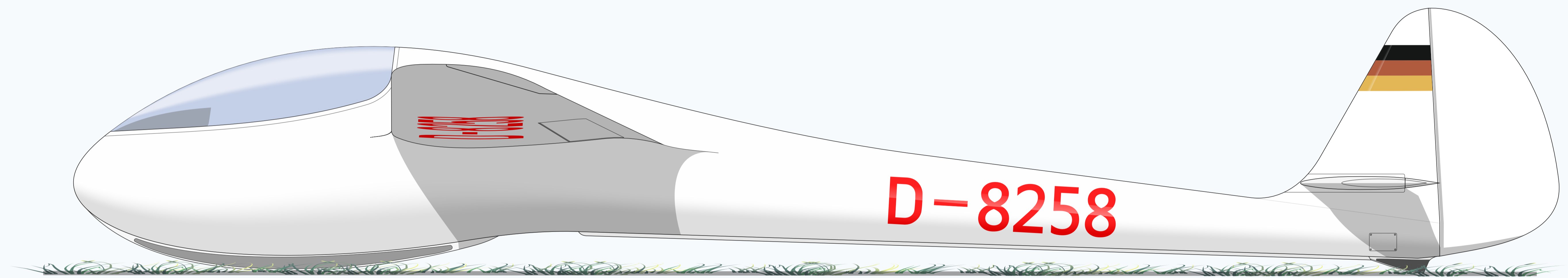

Maßstab/Scale



**FS-24 Phönix**

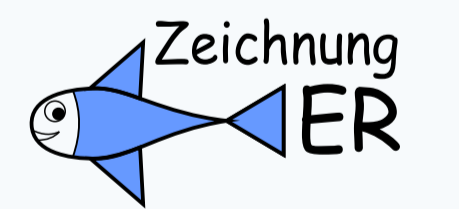

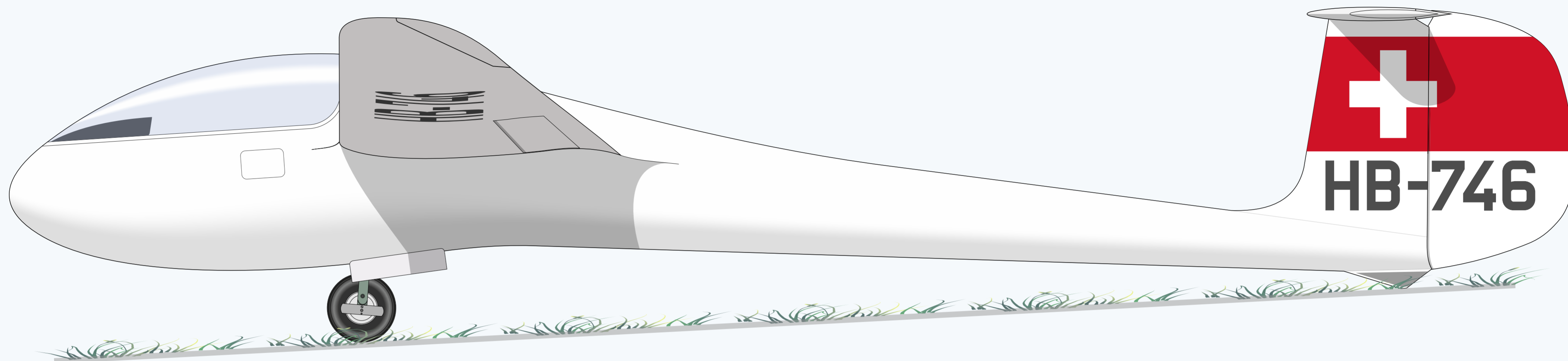

**FS-24**

**PHONIX-T  
NR. 0403**

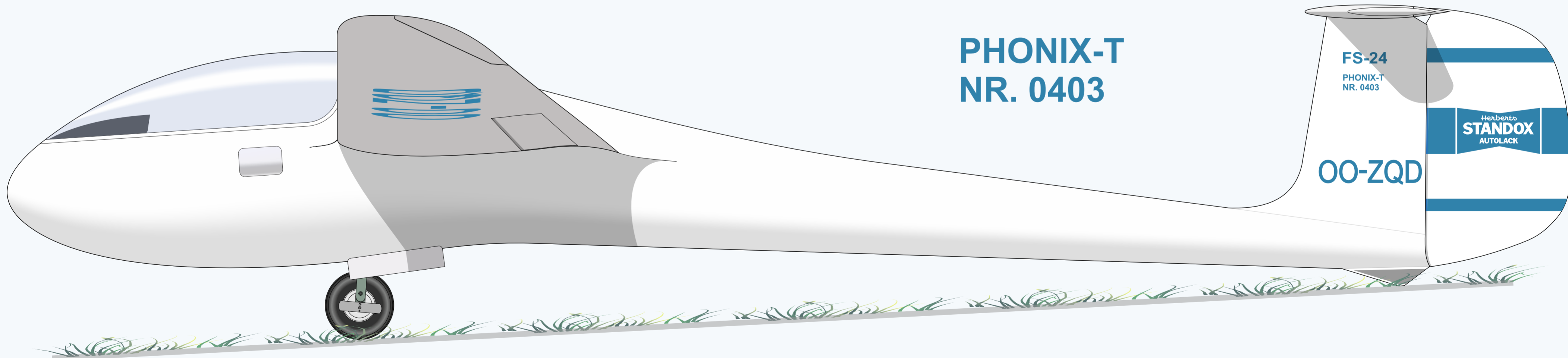

Maßstab/Scale



**FS-24 Phönix T**

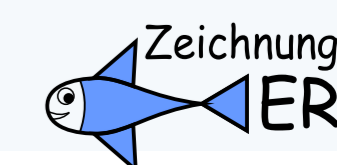



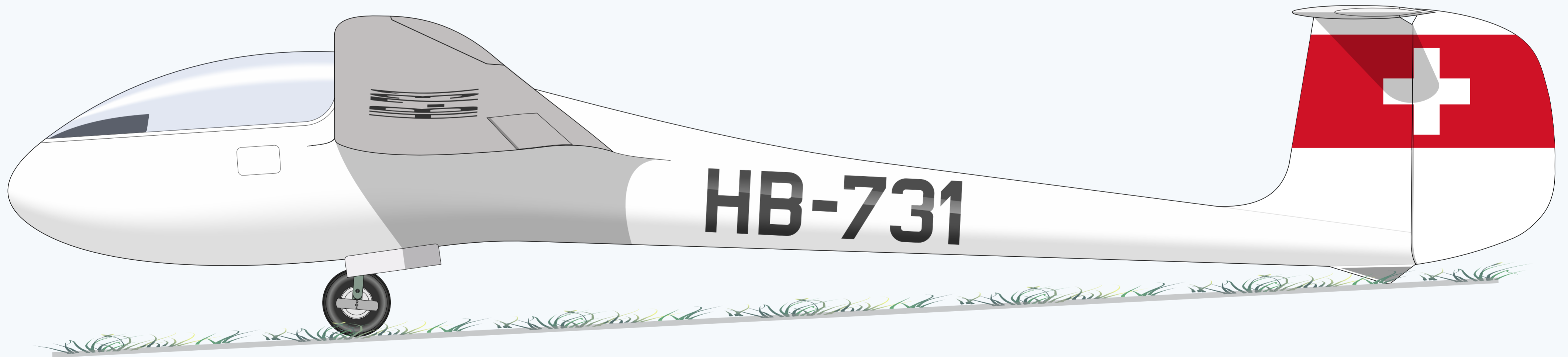
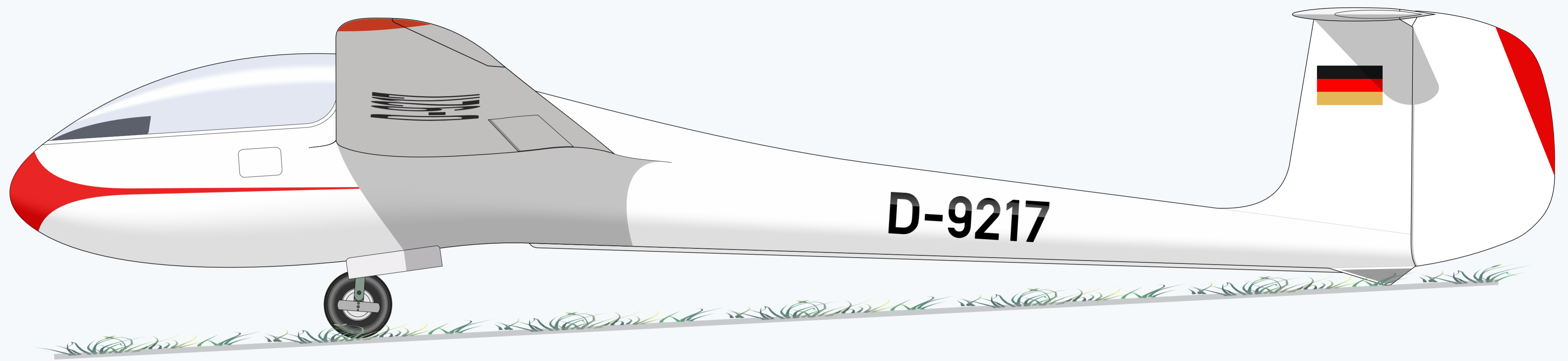

Maßstab/Scale



**FS-24 Phönix T**

